



# DripDoser 1.0



## Getting Started

**Use this guide to install and Setup  
your DripDoser unit.**

(Also contains maintenance and troubleshooting tips)



# Table of Contents

<b>Getting Started with your new DripDoser .....</b>	<b>2</b>
<b>Before you Start.....</b>	<b>3</b>
<b>DripDoser Installation Kit Checklist.....</b>	<b>5</b>
<b>Mounting the DripDoser .....</b>	<b>6</b>
<b>Connecting the DripDoser to Power .....</b>	<b>8</b>
<b>Setting the Oil Drip Rate.....</b>	<b>11</b>
<b>DripDoser PCB Mother Board .....</b>	<b>12</b>
<b>Operating the DripDoser .....</b>	<b>13</b>
<b>Oil Flow Control .....</b>	<b>16</b>
<b>Oil Off/On Control .....</b>	<b>16</b>
<b>Setting the Oil Drip Range .....</b>	<b>17</b>
<b>Adjusting the Drip Rate .....</b>	<b>18</b>
<b>Alarm States .....</b>	<b>19</b>
<b>Resetting the DripDoser .....</b>	<b>19</b>
<b>Trouble Shooting .....</b>	<b>20</b>
<b>DripDoser Unit Specifications .....</b>	<b>23</b>
<b>Ensure Optimal DripDoser Functionality .....</b>	<b>24</b>
<b>Enabling DripDoser Automation .....</b>	<b>25</b>
<b>Product Warranty .....</b>	<b>26</b>
<b>DripDoser Failure .....</b>	<b>26</b>

## Getting Started with your new DripDoser

The DripDoser controls the amount of oil that is supplied to the line shaft. The DripDoser is an active vertical line-shaft lubrication dosing device that helps you save time and money.

The DripDoser automatically controls the amount of oil flowing to the line shaft by opening and closing the solenoid membrane to allow the exact volume of oil flow through the DripDoser.

1. **Protection** - Protects your irrigation vertical turbine pump from going dry.
2. **Detection** – Detects if there is any oil loss in your system.
3. **Blockages** – Detects if there are any clogged or pinched delivery input or output lines.
4. **Control** – Shutdown the pump and provides you with a fail-safe oil output alarm.
5. **Prevention** – Reduces the overall oil consumption and prevents ground water well contamination by providing the exact amount of oil required.
6. **Monitor** – Remote control and monitoring, providing peace of mind.

## Before you Start

Before you start make sure that you have prepared your well site according to the following pre-requisites.

1. **Power Socket** – Ensure that you have an electric power connection next to the well pump.  
**(110 VAC, 220 VAC or 24 VDC)**
2. **Standard Mounting Pole** – Ensure that you have a vertical pole next to the well pump with an attached back plate bracket for mounting the DripDoser.

**Large Oil Tanks** – When mounting the DripDoser on large oil tanks (35 – 50 gallons) mount it on the oil tank stand.

3. **Oil Filter** – Make sure to install an oil filter on the “oil inlet”, and replace the filter every six months.



### **IMPORTANT NOTE – Gravity Feed**

When mounting the DripDoser ensure that the relative spacing between the oil tank, the DripDoser, and the line-shaft inlet is set according to the illustration.

## Gravity Feed

Ensure that the angle of the copper tube is enough for gravity flow from the DripDoser to the line shaft.

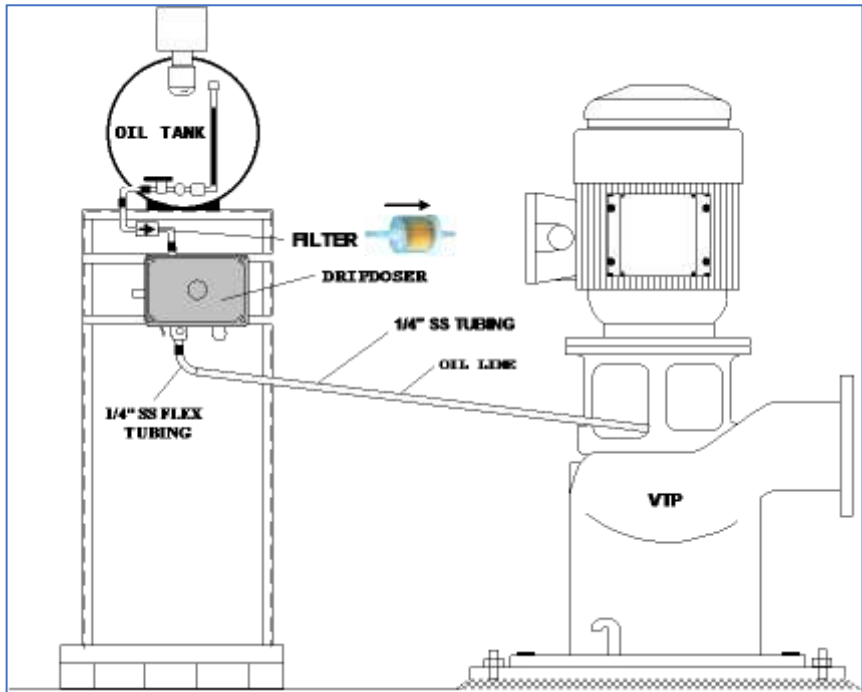

## **DripDoser Installation Kit Checklist**

You are now ready to start installing your new DripDoser. Before you start, ensure that you have the following components in the kit.

**The DripDoser is supplied with the following parts:**

- 1. The DripDoser**
- 2. 4 Mounting bolts**
- 3. 8 Nuts**
- 4. 8 Lock washers**
- 5. 1 Oil filter**
- 6. The DripDoser drilling template**

## Mounting the DripDoser

**Perform the following steps to mount the DripDoser.**

1. Start by drilling the four mounting holes for the DripDoser. Use a  $\frac{1}{4}$  inch drill bit.

Drill two horizontal holes 6.93" (176mm) apart, and then drill two holes beneath the two holes at a distance of 3.78" (96mm) under the two horizontal holes.

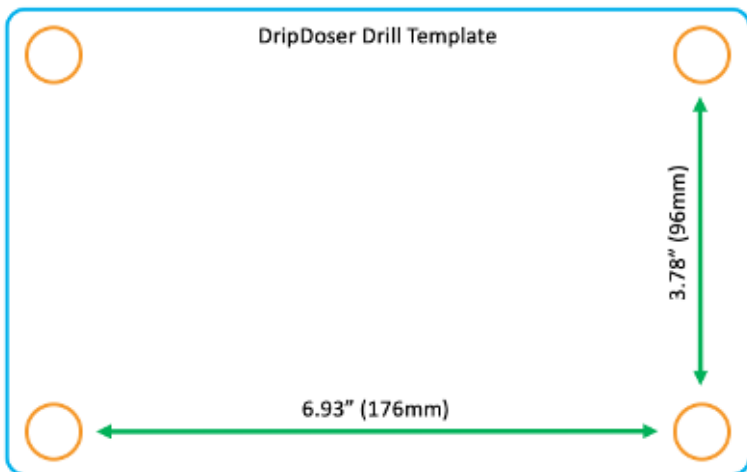



2. Remove the DripDoser front cover and insert the bolts through the unit and secure them to the mount that you have prepared.

**(Use the provided nuts and lock washers for this step).**

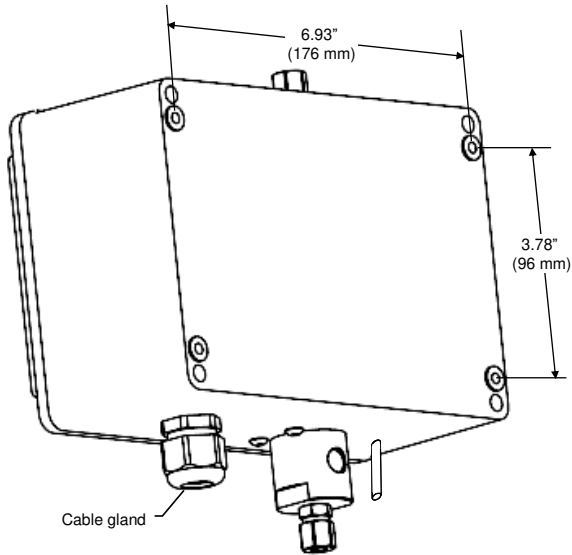

3. Install the inlet oil filter, making sure that the filter is placed in the right direction.



## Connecting the DripDoser to Power

Its now time to connect your DripDoser to electricity. Perform the following steps to connect your unit to power.

1. **Electrical Power Cable** - Use 18 AWG wiring for the power, pump and alarm cable.
2. Feed the power and control cable through the “Cable Grand” found on the bottom of the box.  
**(See, previous illustration)**
3. Connect the green ground wire to the chassis screw on the board. (Preferably using a ring terminal).
4. Connect the power, drip, pump and alarm cable to the wiring terminals.

Connection Name	Terminal block #
ALARM – 1x	1
ALARM – 2	2
PUMP – C	3
PUMP – N.O.	4
24VDC – (+)	5
24VDC – (-)	6
AC PWR (100 or 240V) – L1	7
AC PWR (100 or 240V) – L2	8
CHASSIS GROUND	Chassis screw

5. Ensure that your wiring matches the diagram.

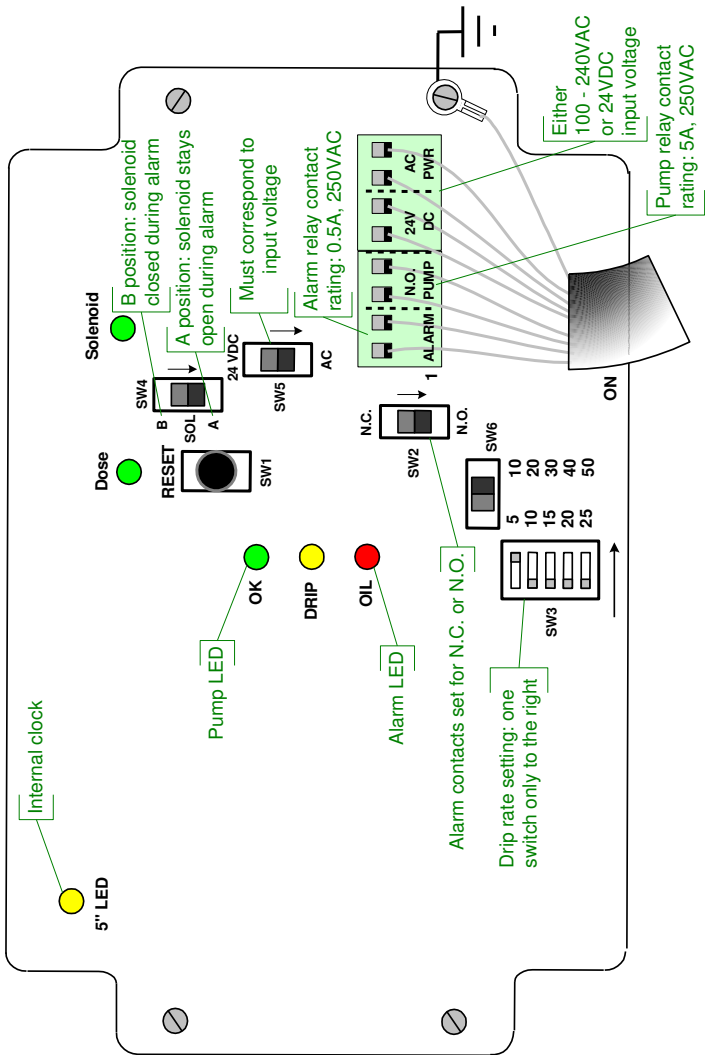

6. Connect the DripDoser oil outlet to the well shaft using flexible ¼ inch copper piping or stainless-steel tubing.

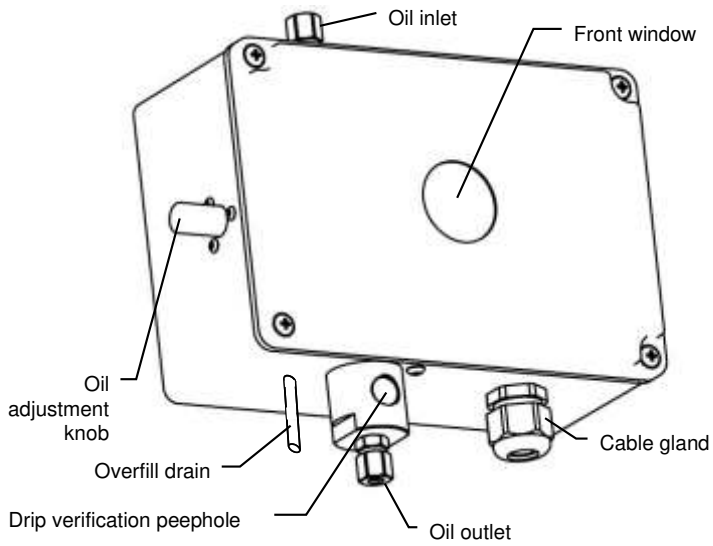

## Setting the Oil Drip Rate

Now it's time to set the oil drip rate for your DripDoser unit.

1. Open the DripDoser cover by removing the four cover screws.
2. Go to the PCB card and set the drip rate using the drip range switch (SW6) number 9 and the drip rate switch (SW3) number 10.

### SW6 - Drip Range Switch (9)

The drip rate switched left = 2-minute cycle

The drip rate switched right = 1-minute cycle

### SW3 Drip Rate Switch - Red switch box (10)

This switch determines the amount of drips per minute.

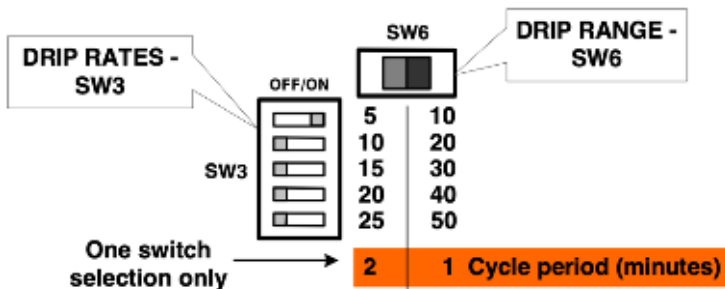

### EXAMPLE 5 PDM Setting (above picture)

**(ONLY ONE SW3 SWITCH CAN BE SET TO THE RIGHT POS.)**

If you set the SW6 to the LEFT (2 min cycle) and the SW3 switch is set to the right position, then it will provide 5 drips per minute.

## DripDoser PCB Mother Board

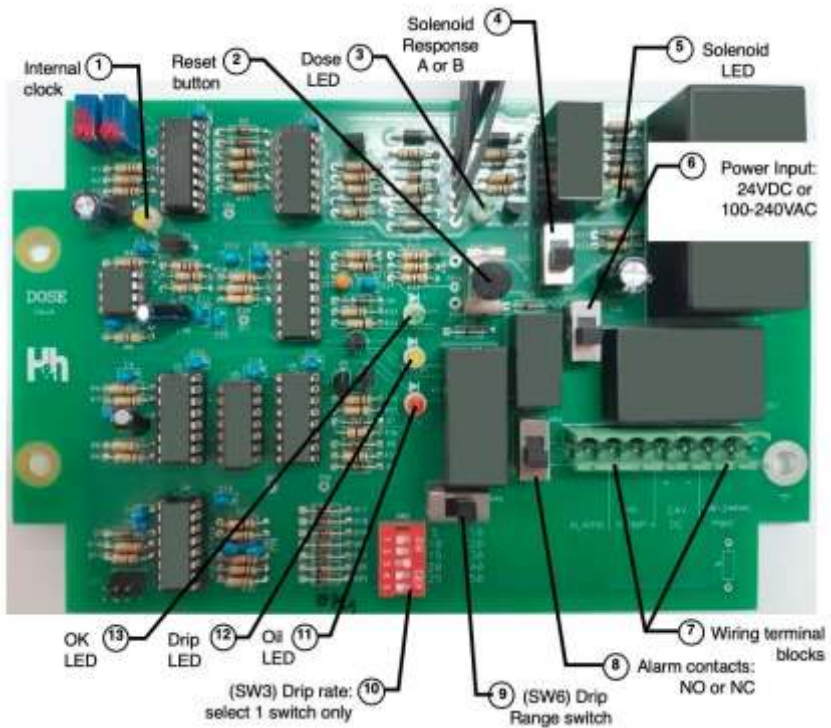

3. Put back the DripDoser cover and tighten the four screws.

## Operating the DripDoser

The following table details the PC board functionality and settings.

Board Item	Name	Control or Indicator	Function
2	Reset Button	Push button	Resets the DripDoser
4	Solenoid Response A or B	Slide switch SW4	Position A (Down) to protect machinery. Keeps solenoid open during an alarm. (Continues during alarm) Position B (Up) to protect environment. Closes solenoid during an alarm. (Stops during alarm)
6	Power Input	Slide switch SW5	Selects 24 VDC or AC input voltage (100 – 240 VAC).
7	Wiring terminal	Terminal blocks	Input voltage, pump and alarm connections.
8	Alarm contact NO or NC	Slide switch SW2	Provides either NO or NC contacts for the alarm.
9	Drip range	Slide switch SW6	Selects on of two ranges. Range A: (5, 10, 15, 20, 25) dpm with period T = 2 minutes. Range B: (10, 20, 30, 40 or 50) dpm with period T=1 minute.
10	Drip rate switch	DIP toggle switch SW3	Selects the desire Drip per minute (DPM)

**\*ATTENTION DURING ALARM STATE:**

It is operator's decision to select the A or B position of SW4. An alarm state can be caused by continuous oil flow (oil adjustment is not restricted sufficiently) or insufficient oil flow.

During an alarm state: If the SW4 switch is in the A position, then the solenoid stays open continuously. Oil waste and well contamination may occur, but the pump is protected. The Solenoid LED is on.

If the SW4 switch is in the B position, the solenoid is closed and the pump is unprotected. Waste or well contamination will not occur, but the pump is unprotected. The Solenoid LED is off.

1	Internal clock	Yellow LED	Factory use only
3	Dose LED	Green LED	Indicates that the lubrication cycle has completed successfully.
5	Solenoid LED	Green LED	Indicates that the solenoid is on (activated).
11	Oil ALARM	Red LED	Indicates that the amount of oil delivered is less than the oil drip rate setting on SW3. The PUMP N.O. contacts open and the ALARM N.O./N.C. contacts open/close when the OIL (alarm) LED lights. The OIL (alarm) LED turns off when resetting the DripDoser.
12	Drip LED	Yellow LED	This LED flashes for each drop of oil that passes through the DripDoser.
13	OK PUMP LED	Green LED	Indicates that sufficient oil is supplied to the lineshaft,



			<p>matching the dpm setting on SW3.</p> <p>The PUMP N.O. contacts close and the ALARM N.O. /N.C. contacts close/open when the OK (PUMP) LED is on. The pump relay contacts can be used to turn off the well pump and the alarm relay contacts can be used to activate an external lamp/horn.</p>
--	--	--	--

## Oil Flow Control

Oil flows through the DripDoser from the oil inlet to the oil outlet and is controlled by a built-in solenoid and the oil adjustment knob.

## Oil Off/On Control

The solenoid is powered by the DripDoser power source. When the DripDoser is powered up, and the selected number of drops passes through the DripDoser, then the solenoid turns off until the next 1 or 2-minute duty cycle. The solenoid is turned off when there is no power supply or the DripDoser is in the alarm state with the solenoid A/B switch (SW4) in the B (closed) up position.



### **IMPORTANT NOTE**

Setting the SW4 switch to Position A (Down)  
Keeps solenoid open during an alarm (i.e.  
DripDoser keeps on dripping)

## Setting the Oil Drip Range

Select one of the two drip rate options A or B. (SW6)

**Range A – (SW6 Switch to the right)** The Range A oil drip rates are selectable for 10, 20, 30, 40, or 50 drips per minute with a period of 1 minute.

**Range B - (SW6 Switch to the left)** The Range B oil drip rates are selectable for 5, 10, 15, 20, or 25 drips per minute with a period of 2 minutes.

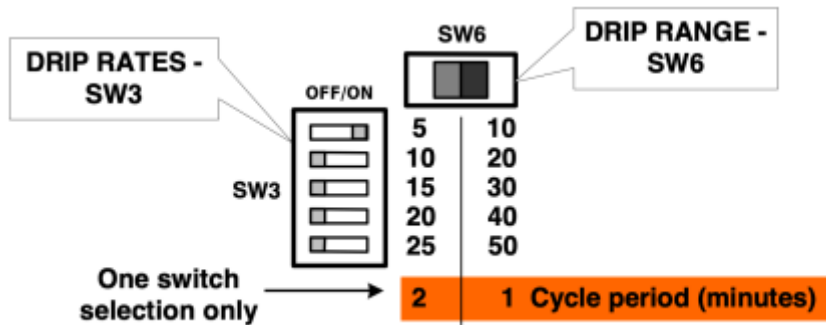

## Adjusting the Drip Rate

1. Select the desired range of drops with the SW6 Switch.
2. Select the required number of drops/minute (dpm) on the drip rate switch SW3.
3. Make sure that oil can flow through the DripDoser.
4. Rotate the oil adjustment knob so that the solenoid LED is on for 10 – 20 seconds. Turning the oil adjustment knob CCW (counter-clockwise) increases the drip flow rate.

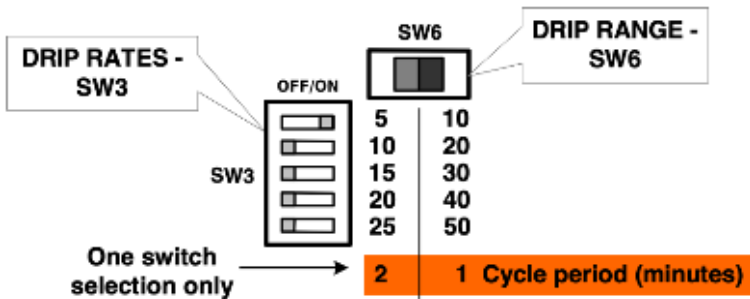

### IMPORTANT NOTE

If the OIL (alarm) LED is on during any time of the oil adjustment, you need to reset the PC board using the reset button

If the solenoid LED is turned off before the adjustment is made, reset the unit and continue adjusting the drip rate without waiting.

## Alarm States

During an alarm, the red Oil LED is activated, indicating that the oil dosing has not been achieved during the one/two minute duty cycle. The alarm state will occur under the following conditions:

1. Loss of oil in the oil tank.
2. Clogged input or dirty input filter.
3. Blocked outlet line.
4. The oil adjustment knob setting is too restrictive, causing an insufficient amount of oil to pass to the outlet.
5. The oil adjustment knob setting is allowing too much oil to pass through the DripDoser, resulting in a continuous flow of oil (instead of oil drops).

## Resetting the DripDoser

There are two methods for resetting the DripDoser:

1. The first, by removing the DripDoser cover and pressing the Reset push button.
2. The second, by disconnecting the power source to the DripDoser and then reconnecting it.



### **NOTE**

In both cases, circuit voltage is interrupted and then restored.

## Routine Maintenance

The following table provides maintenance information for the DripDoser unit.

Task	Frequency
Check for oil leaks	Monthly
Fully open the oil adjustment knob (turn fully CCW) for 5 seconds to clear obstructions that might have accumulated.	Annually
Change the oil inlet filter periodically	6 – 12 months

## Trouble Shooting

The following table details the trouble shooting methods for your DripDoser unit.

Problem	Possible Cause	Solution
No LEDs are lit.	The unit is not powered.	Check power source. Confirm that SW5 setting is correct. See
No oil dripping – oil does not appear in oil peephole, nor does the Drip LED flash periodically.	Partial or complete blockage in the input or output. Oil adjustment knob opened too much. Empty oil tank.	Make sure lines are clear and filter is clean. Make sure the oil adjustment knob is set correctly. Fill empty oil tank.

Problem	Possible Cause	Solution
The OIL (alarm) LED is on.	<p>Oil tank is empty</p> <p>A shut-off valve at the outlet of the oil tank might be closed</p> <p>Oil flow from the oil tank may be obstructed.</p>	<p>Refill the oil tank</p> <p>Open the shut-off valve</p> <p>Clean out any obstructions in the pipe between the oil tank and the DripDoser inlet</p>
	<p>Oil blockage between the DripDoser outlet pipe and the line-shaft.</p>	<p>Clean out any obstructions in the delivery line between the DripDoser outlet and the line-shaft, or replace the delivery line.</p> <p><b>Note:</b> Reset the DripDoser after fixing the problem.</p>
	<p>The oil adjustment knob needs to be re-adjusted.</p>	<p>Rotate the oil adjustment knob so that the solenoid LED is on for 10 – 20 seconds.</p>

## DripDoser Unit Dimensions

The DripDoser enclosure is made of cast aluminum and painted with a protective coat of weather resistant paint.

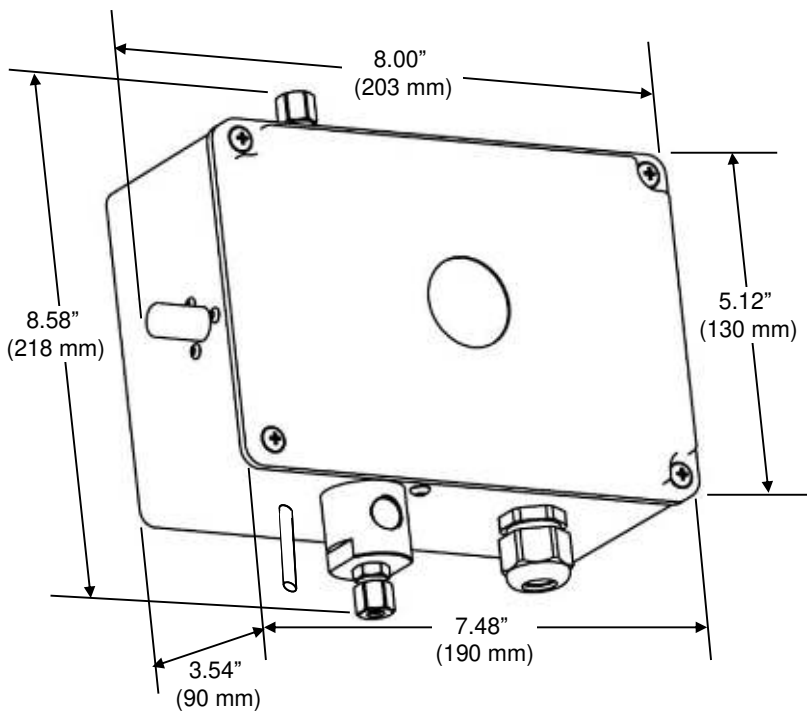



## DripDoser Unit Specifications

Supply voltage	100 to 240 VAC, 50/60 Hz, or 24 VDC
Power consumption (max.)	10 W
Drip rate drip rate settings	5, 10, 15, 20, 25 dpm for range A, 2 minute cycle 10, 20, 30, 40, 50 dpm for range B, 1 minute cycle
Pump Shutdown relay contact	AC: 5A DC: 5A
Alarm relay contact	AC: 0.5A DC: 0.5A
Oil on/off solenoid	12 VDC (internal voltage)
Drip volume	32 drops per 1 cc
Oil inlet/outlet	Male thread ¼" BSP
Unit Dimensions (W x H x D)	8.58 x 8.00 x 3.54 inches (218 x 203 x 90 mm)
Weight	3.7 lbs. (1.7 kg)

## Ensure Optimal DripDoser Functionality

Setting the proper adjustment of the drip rate by manually adjusting the needle valve at the installation stage will ensure that your unit works at an optimum. Also, ensure that the drain tube does not have any buckles and it flows smoothly.

Ensure that the oil flows freely.

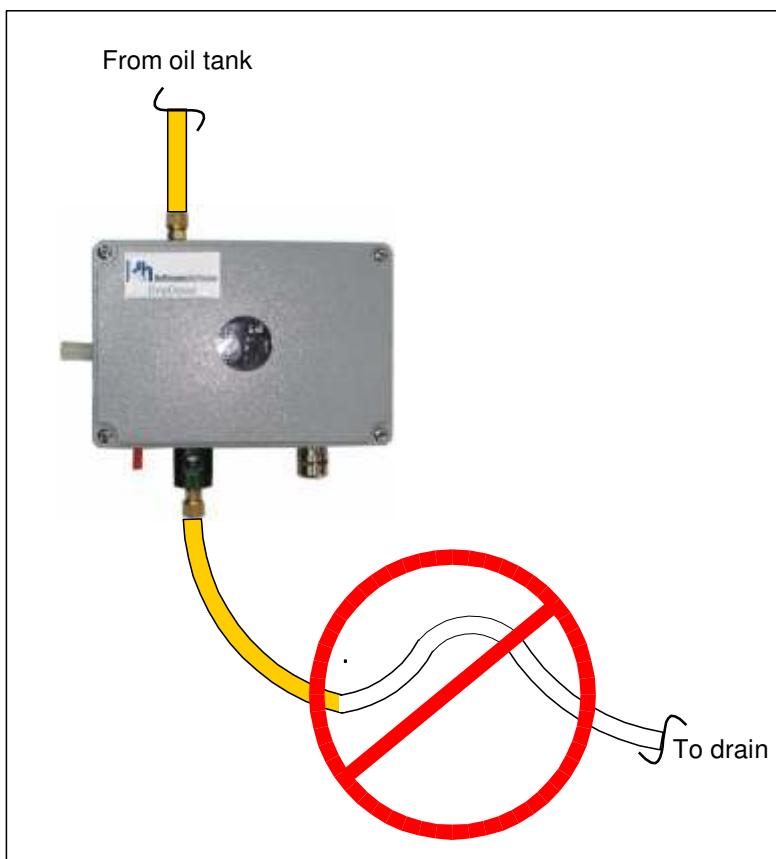

## Enabling DripDoser Automation

Ensure that the solenoid switch is set to the “ON” position to enable all of the DripDoser device functionality.

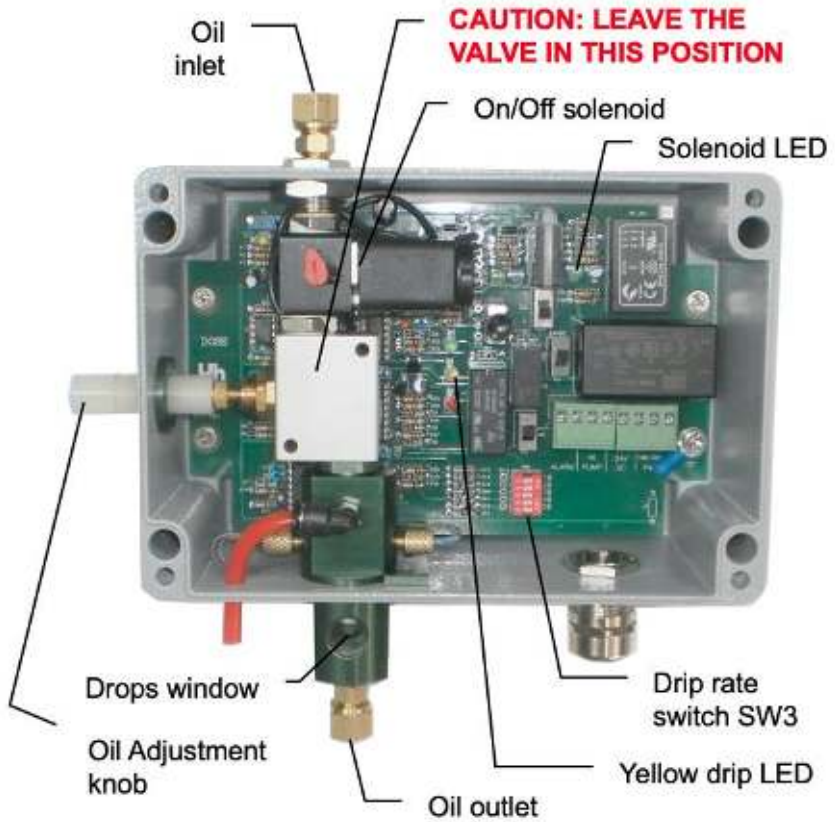

## **Product Warranty**

All Hoffmann & Hoffmann products have a two-year limited warranty.

H&H is not responsible for damages caused by improper installation and external factors, i.e. temperature extremes, power surges or if the owner breaks or damages the DripDoser unit.

## **DripDoser Failure**

If a DripDoser unit failure occurred during the Warranty Period, H&H will cover the repair cost. The customer will only pay for the shipment and handling to the nearest H&H dealer.

